

**EYE 200: ecos, DDC Individual-room controller**

For individual temperature control of separate rooms according to the levels of occupation. Using the EYB 251...256 and EYB 270 operating units, any function can be selected from inside the room.

Functions: window contacts, occupancy detection, ventilator control and dew-point monitoring. Used with a data interface, it is suitable for connecting to the EY3600 building management system. Housing of fire-retardant thermoplastic in white (RAL 9010). The parameters, application program, calendar function and historical data are stored in a battery-backed RAM. The application program can also be stored in a user-EPROM. Compact unit for fitting side-by-side (DIN 43880) on 35-mm top-hat rail as per EN 50022. Terminals for max. 2,5 mm<sup>2</sup>.



T10363

| Type                     | Description                    | Relay outputs                 | Power                      | Weight kg |
|--------------------------|--------------------------------|-------------------------------|----------------------------|-----------|
| <b>EYE 200 F001</b>      | DDC individual room controller | 3                             | 230 V~                     | 0,7       |
| <b>EYE 200 F002</b>      | DDC individual room controller | 4                             | 230 V~                     | 0,7       |
| Power supply 230 V~      | ± 10%, 50/60 Hz                | Wiring diagram                | <a href="#">A10360</a>     |           |
| Power consumption        | 14 VA; incl. 6 VA external     | W × H × D                     | 178 × 103 × 53             |           |
| Power loss               | 14 W                           | Dimension drawing             | <a href="#">M10361</a>     |           |
| Degree of protection     | IP 10                          | Fitting instructions          | MV 505907                  |           |
| Protection class         | I                              | Declaration of materials used | MD 94.200                  |           |
| Perm. ambient temp.      | 0...45 °C                      | Complies with:-               |                            |           |
| Perm. ambient humidity   | < 85 %rh                       | EMC directive 2004/108/EC     | EN 61000-6-1/ EN 61000-6-2 |           |
| Environment class        | IEC 60721 3K3                  |                               | EN 61000-6-3/ EN 61000-6-4 |           |
| <b>Inputs</b>            |                                | <b>EYE 200 F001</b>           | <b>EYE 200 F002</b>        |           |
| for operating unit       | EYB 250...256, EYB 270         | 1                             | 1                          |           |
| for temperature sensor   | Ni1000                         | 1                             | 1                          |           |
| for control contacts     | on/off                         | 2                             | 2                          |           |
| <b>Outputs</b>           |                                | <b>EYE 200 F001</b>           | <b>EYE 200 F002</b>        |           |
| Triac: switching outputs | 0-I-II (24 V~, 1 A)            | 2                             | 2                          |           |
| Relay: switching outputs | NO (250 V~, 2 A)               | 3                             | 3                          |           |
| Relay: switching outputs | NO (250 V~, 10 A)              | 0                             | 1                          |           |
| Analogue                 | 0...10 V (load ≥ 1 kΩ)         | 2                             | 2                          |           |

**Engineering notes**

The unit must be protected against accidental physical contact.  
The max. output of Ls is 6 VA.

| MFA | Type of address  | EYE 200 F001 |             | EYE 200 F002 |             |
|-----|--|--------------|-------------|--------------|-------------|
|     |  | HDB          | Terminals   | HDB          | Terminals   |
| 04  | Temperature measurement Ni1000 (range: -10...95 °C)                  | *            | 11-⊥        | *            | 11-⊥        |
| 09  | Temperature measurement Ni1000 (operating unit) (range: -10...95 °C) | *            | 3-2-⊥       | *            | 3-2-⊥       |
| 10  | Potentiometer measurement (operating unit) (basic setting: ± 2°)     | *            | 3-2-⊥       | *            | 3-2-⊥       |
| 20  | Analogue output 0 (2)...10 V d.c.                                    | *            | 4-⊥         | *            | 4-⊥         |
| 21  | Analogue output 0 (2)...10 V d.c.                                    | *            | 5-⊥         | *            | 5-⊥         |
| 32  | Digital output 0-I-II (triac, 24 V a.c., 1 A)                        | *            | LS-17-18    | *            | LS-17-18    |
| 33  | Digital output 0-I-II (triac, 24 V a.c., 1 A)                        | *            | LS-14-15    | *            | LS-14-15    |
| 34  | Digital output 0-I (relay, 250 V a.c., 10 A)                         | -            | -           | *            | 19-20       |
| 35  | Digital output 0-I-II-III (relay, 250 V a.c., 2 A)                   | *            | 21-22-23-24 | *            | 21-22-23-24 |
| 40  | 'Normal operation' signal MFA 56 (0-I-II)                            | *            | internal    | *            | internal    |
| 41  | 'Normal operation' signal MFA 57-1 (0-I-II-III)                      | *            | internal    | *            | internal    |
| 42  | Rotating circuit from MFA 56 0-I-II-0...                             | *            | internal    | *            | internal    |
| 43  | Rotating circuit from MFA 57 0-III-II-I-0...                         | *            | internal    | *            | internal    |
| 50  | Quantity counter // to MFA 52  | *            | 7-⊥         | *            | 7-⊥         |
| 51  | Quantity counter // to MFA 53  | *            | 9-⊥         | *            | 9-⊥         |
| 52  | Contact input  | *            | 7-⊥         | *            | 7-⊥         |
| 53  | Contact input  | *            | 9-⊥         | *            | 9-⊥         |
| 56  | Contact input, button 0-I-II (operating unit)                        | -            | 3-2-⊥       | -            | 3-2-⊥       |
| 57  | Contact input, button 0-I-II-III (operating unit)                    | -            | 3-2-⊥       | -            | 3-2-⊥       |

**Wiring diagram**

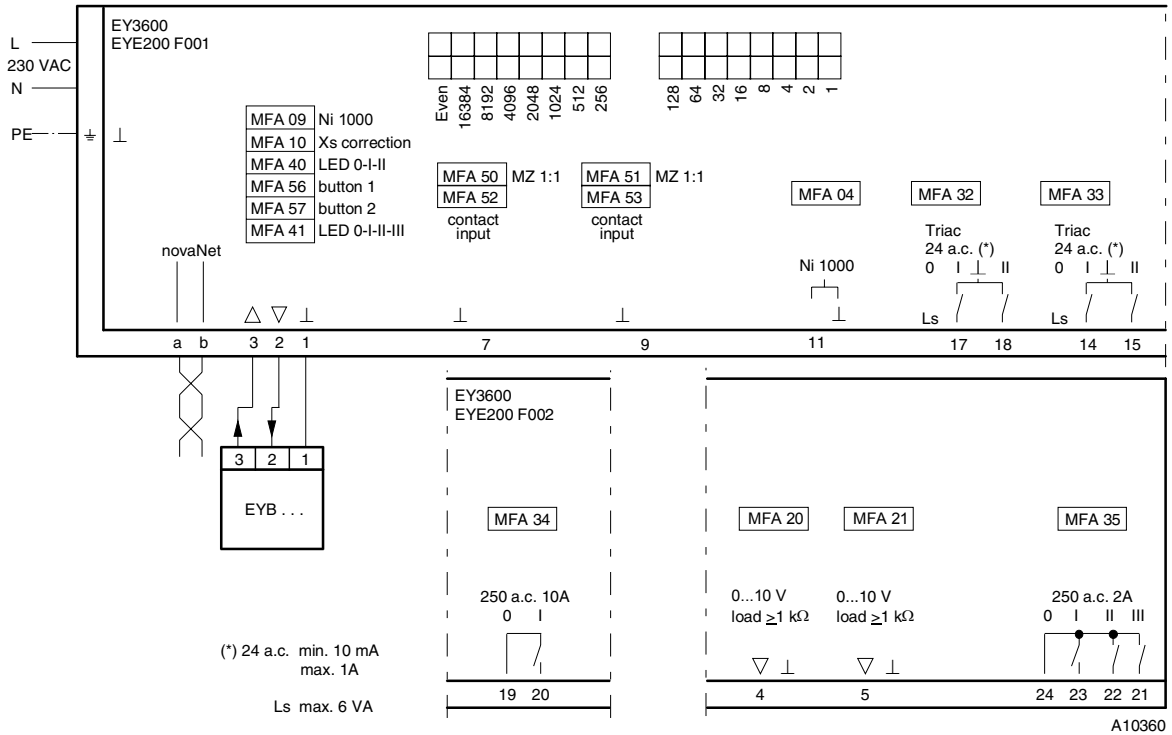

In cases where the industry standard (EN 61000-6-2) has to be met, the power cables for the analogue inputs/outputs (AI/AO) and the power cable to the EYB operating units should be no longer than 30 m.

**Dimension drawing**

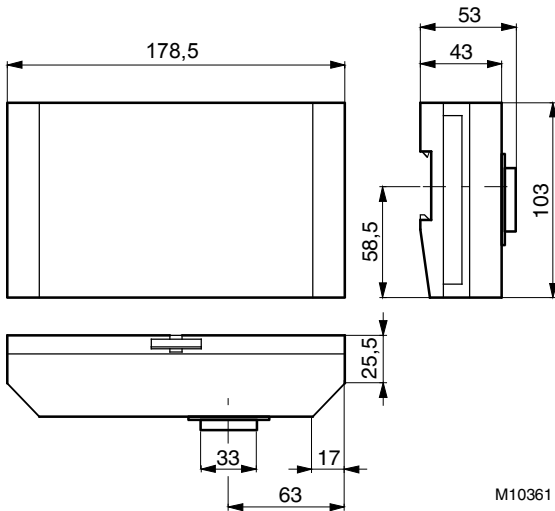

**Engineering notes**

The *ecos 200* intelligent unitary controller can be fitted to a top-hat rail (EN 50022). It requires a power supply of 230 V~. The body terminals are connected to earth (PE) (24 V~ PELV). The devices are connected via screw-type terminals. The following requirements must be fulfilled:-

- Cross-section of wires: Min. 0.8 mm<sup>2</sup> (AWG 18), max. 2.5 mm<sup>2</sup> (AWG 13), observing the standards.
- novaNet:** With twisted cable, max. expansion 200 nF/300  $\Omega$ , rating 0.3 nF per device.
- Digital inputs, counter: Potential-free contacts, opto-coupler, transistors (open collector). Open: > 3.5 V. Closed: < 1V.
- Digital outputs: 250 V~/2(2) A to the relay contacts (3-speed fan). 250 V~/10(10) A to the relay contact (electric re-heater). 24 V~/1A to the triacs.
- Analogue outputs: No external voltage. 0...10 V =, < 10 mA.

**Important notes**

**ecos 200** has 128 MFAs and can store 2x 1792 entries in the HDB.

**Time:** The time freezes in the event of a power failure. The internal clock does **not** have a back-up, so it is essential that the time is synchronised once per day.

**Sizing the internal transformer**

The internal transformer is designed for a loading of max. 6 VA for all triac outputs (one AXT 111 thermal drive).

**Parallel operation of several thermal drives**

- 1 Drives supplied with power by external transformer. Triac loading: max. 1 A
- 2 Drives supplied with power by semi-conductor relays (the number of drives is limited by the rating of the semi-conductor relay). Semi-conductor relays can be ordered from stock from SRF.  
 Examples: 24 to 280 V~, 8 A without heat sink at 230 V~, control voltage 18...36 V~.  
 24 to 280 V~, 16 A without heat sink at 230 V~, control voltage 18...36 V~.

Use of continuous drives for unit valves with AXS positioner.  
 The 0...10 V output on the *ecos 200* can control up to 15 AXSs.

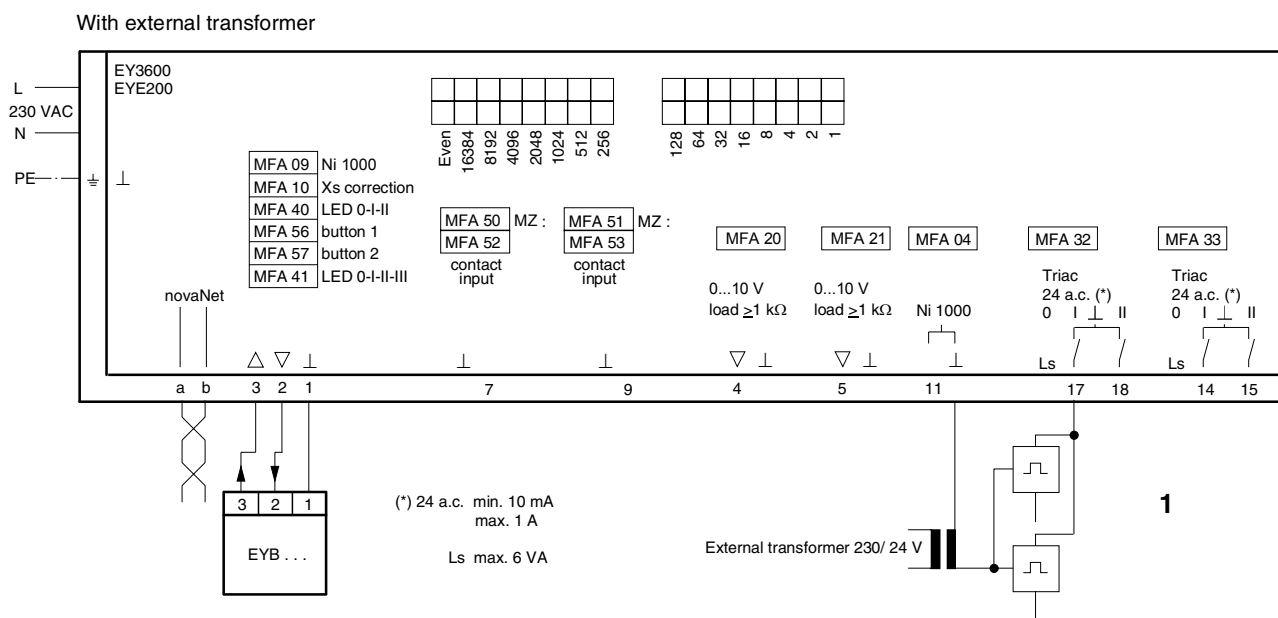

With semi-conductor relay

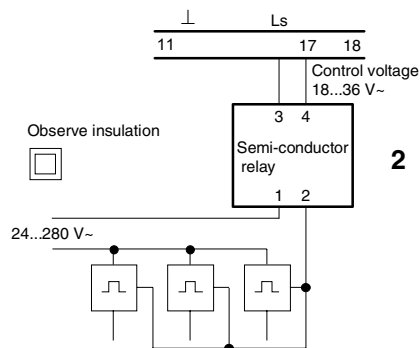

**Examples of use**

Fan-coil temperature controller with 4-pipe system

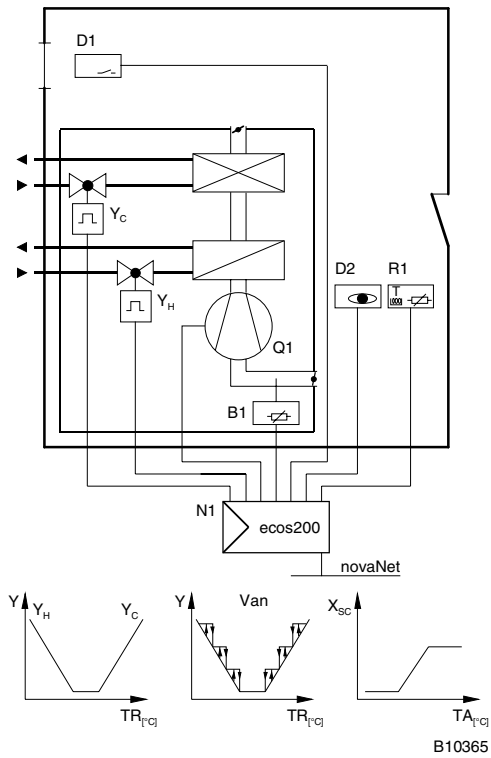

Fan-coil temperature controller with 4-pipe system  
Heating via radiators

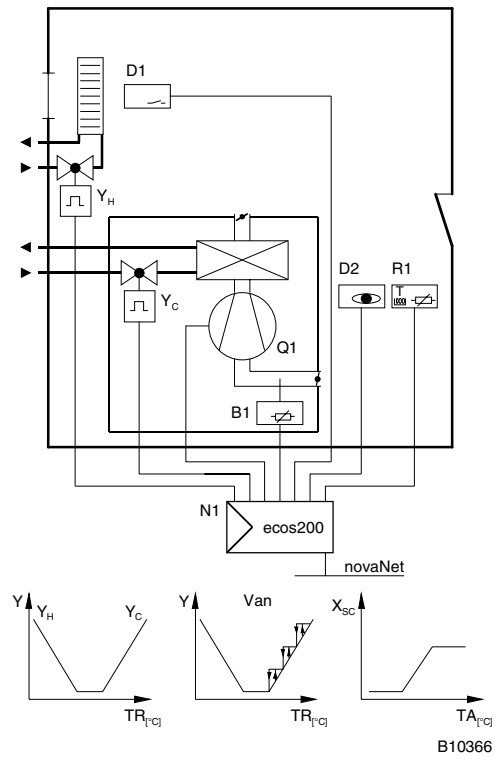

Chilled-beam control system  
Heating via fan-coil

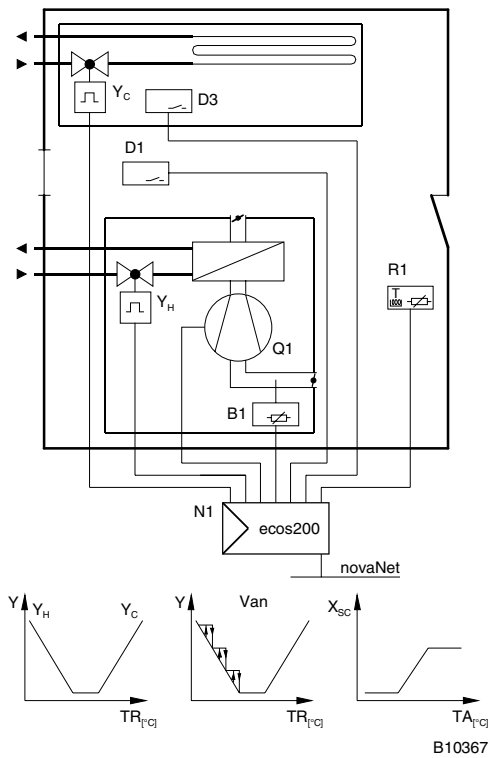

Fan-coil temperature controller with 2-pipe system  
Heating/cooling via change-over

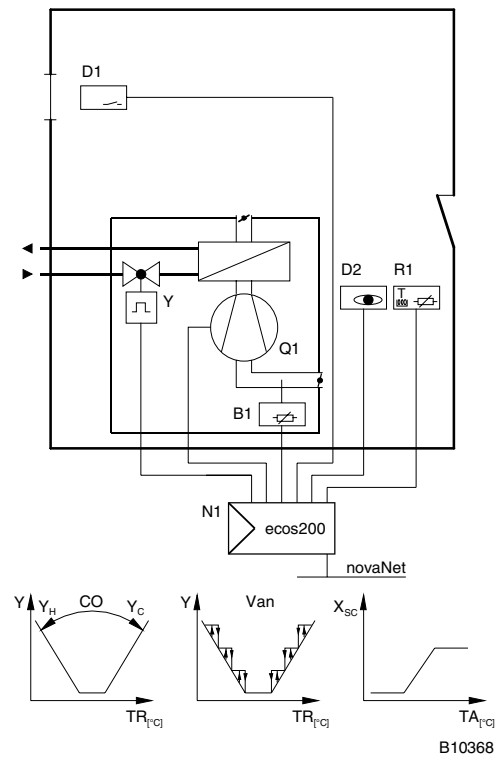

**Key**

- B1 Duct sensor
- D1 Window contacts
- D2 Occupancy detector
- D3 Dew-point monitor

- N1 Controller
- Q1 Ventilator
- R1 Room operating unit

- Y Heating/cooling valve
- Yc Cooling valve
- YH Heating valve